

MAXIMIZE HARVEST

*Cutting-Edge Vibration Technology
For Fertilizer Tenders & Spreaders*



VIBCO[®]
VIBRATORS

SOLVING MATERIAL FLOW & COMPACTION SINCE 1962

VIBCO

SERVING AGRICULTURAL MARKETS SINCE 1962

Welcome to the Vibration Nation . . .

where excellence in vibration engineering meets American craftsmanship. We're dedicated to providing you with top-tier vibration products that are not just engineered for quality, but crafted for longevity.

Backed by over 60 years of combined expertise in vibration engineering, our team of skilled engineers ensures that each VIBCO vibrator is meticulously designed using the latest advancements in the field. From concept to creation, we prioritize durability and performance in every aspect of our products. Our highly trained craftsmen and women bring these designs to life with precision and care. The result? Vibration equipment that sets the standard for reliability and durability in the market to power your success.



**Built in the USA,
Trusted worldwide.**

OUR MISSION

Experience the difference with VIBCO Agricultural Vibration Equipment, your key to seamless fertilizer flow.

At VIBCO, progress isn't just a goal; it's in our DNA. We're pioneers, continuously leading the way with cutting-edge products and techniques. Safety and sustainability are our cornerstones, as we meticulously adhere to OSHA Guidelines and Ecology Programs.

Trust in VIBCO for the most comprehensive and dependable line of vibration products, ensuring smoother fertilizer flow precisely when you need it.

Our Mission is "Same Day - Next Day." When you order a standard VIBCO vibrator, it will ship out to you the same day or the next day. Our products are made in the US, right here in Wyoming, RI where we are ready to ship to you quickly



BOLT PATTERNS FIT COMPETITIVE UNITS

Our extensive range of vibration products stands as a testament to our commitment to reliability and completeness. But what sets us apart is our adaptability. Our bolt hole patterns seamlessly integrate with those of other brands, ensuring compatibility without compromise. Simply reach out to us with your specifications, and we'll swiftly provide you with the superior VIBCO vibrator tailored to your exact needs

Experience the VIBCO advantage – where innovation meets reliability, and excellence is always on schedule.

Discover the VIBCO advantage with our **Free 10 Day Trial**. Trusted by over 1 million customers since 1962, our trial program lets you experience the superiority of VIBCO products firsthand. Call us today, and we'll ensure your vibrator is expertly mounted for optimal performance and durability. Solve your material vibration issues risk-free with VIBCO – simply ask for any of our standard units for your 10 Day Free Trial. Your only commitment is to cover freight charges. Contact our engineers at 1-800-633-0032, send your purchase order marked "For Free Trial," and experience excellence, guaranteed.

MADE IN USA 
At 75 Stilson Road, Wyoming, Rhode Island



EASY STEPS TO CHOOSE THE CORRECT UNIT FOR YOUR APPLICATION

Discover the perfect model for your spreaders and tenders by providing accurate answers to the **Inquiry Data Sheets** you can find on-line. Access a range of these sheets with a simple visit to www.vibcovibrators.com/data_inquiry. Here, you will find downloadable PDF files tailored to various bins, hoppers, air cannons, dump bodies, spreaders, and more. Complete the form with your specifics, and we'll pinpoint precisely the vibration product you require. Typically these are the type of questions we need answered:

- What is the total yardage of your spreader?
- What is the length of your spreader?
- What is the width of your spreader?
- What material is your spreader made of: steel, stainless steel, aluminum, plastic, etc.?
- What material are you hauling?
Is the material wet, dry, sticky, etc.?
- How heavy is the material (weight per cubic foot)?
- What issues are you encountering (clinging to the sides, sticking, etc.)?
- What is your power source: electric (12V or 24V), pneumatic (air), or hydraulic?

With these details — and a couple of photos taken with your smartphone — we can provide the assistance you need. We can also provide a **Virtual Van Visit** for easy-to-follow 1, 2, 3 step-by-step mounting procedures.

Visit our Catalog Website (www.vibcovibrators.com) to download digital versions of all our catalogs or order your printed copy. Our new 2024, 84-page color version is available in English, and an 80 page in French (Canadian), and Spanish, with key charts presented in both Imperial (inch) and metric measurements.

All VIBCO vibration equipment is proudly 100% manufactured in the USA, maintaining stringent quality standards since our inception in 1962. We hold numerous US and foreign patents, perpetuating our innovative tradition with a new generation of engineers and skilled craftsmen and women.

When you place your order, many of our models are readily available in stock for same-day or next-day shipping, ensuring prompt delivery. And should you have any inquiries, our technical support team is available 24 hours a day at 1-401-539-2392.

VIBCO VIBRATORS We're The **EXPERT** Vibrator Guys. **FAX: 401-539-2584**
*** = INFORMATION REQUIRED FOR PROPER VIBRATOR RECOMMENDATION**

COMPANY _____
 CONTACT NAME _____
 ADDRESS _____
 PHONE _____
 EMAIL _____
 FAX _____

SPREADERS

Body Material: Steel Stainless Steel Aluminum Plastic Other: _____
 Dimensions: Yardage: _____ Length: _____ Width: _____

V-type Spreader **Tailgate Spreader**

PLEASE INCLUDE
 engineering drawings & digital picture(s) of application & email them to vibrators@vibco.com.
 Or please include dimensions & notes regarding your application/problems on this form
 and fax it to **401-539-2584**.

MATERIAL BEING SPREAD *

Type of Material: _____
 Moisture & Texture: dry damp wet sticky dirt/soil aggregate
 Weight per cubic foot: _____ lbs
 Spreader Problem: sticking to sides sticking to front of body

POWER AVAILABLE * preferred *

AIR Volume: _____ CFM
 ELECTRIC 12 Volt: _____ 24 Volt: _____ Pressure at vibrators (not at compressor): _____ PSI
 HYDRAULIC PSI: _____ GPM: _____

www.vibco.com | 401-539-2392 | vibrators@vibco.com **CLEAR** **SUBMIT**
 DAT_INQ_SPREADER_31520

VIBCO VIBRATORS SPREADER INQUIRY DATA SHEET



DC-300

12 VOLT BATTERY OPERATED UNITS ARE IDEAL FOR FIELD AND MOBILE OPERATIONS

DESCRIPTION

- 12 Volt DC "SandBuster" line of Vibrators (also available in 24V, please call for pricing).
- These models are ideal for field or mobile applications.
- 350 lbs. of force, 16 amps, 4000 RPM, cont. duty
- Wiring kits available for easy installation.
- Fusible connection also recommended.

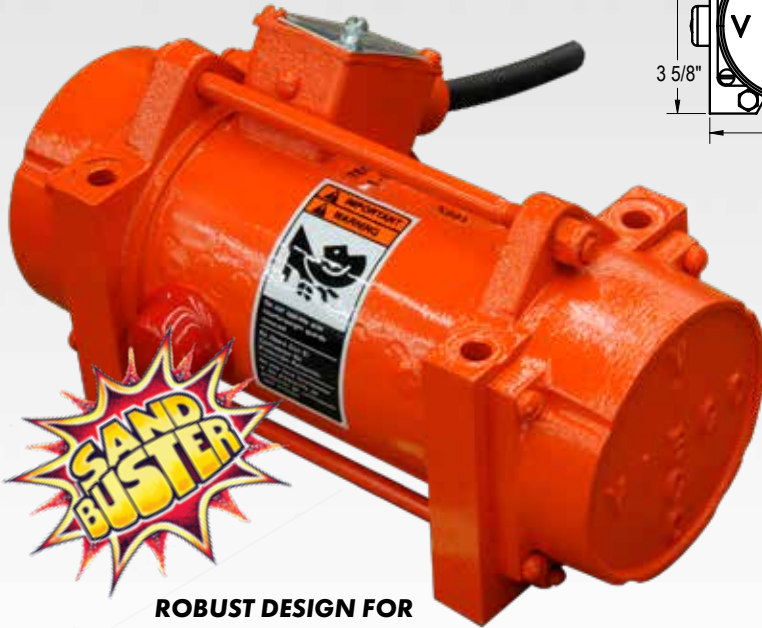

**ROBUST DESIGN FOR
LONG LIFE**

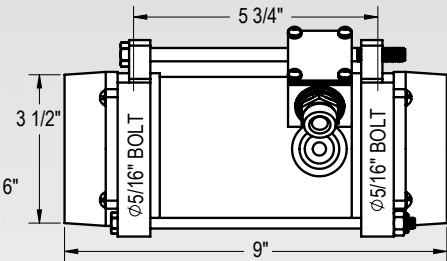
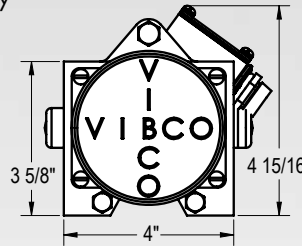

Weight	13.0 lbs	5.9 kg
Force	350 lbs	1,555 Newtons
Amperage	16	8
Volts	12DC	24DC
Max Speed	4000	
dB	74	

*Single Phase
Continuous Operation*



DC-700

AIDS FLOW OF MATERIAL FROM BINS & CHUTES AND FAST DUMPING OF TRUCKS & TRAILERS

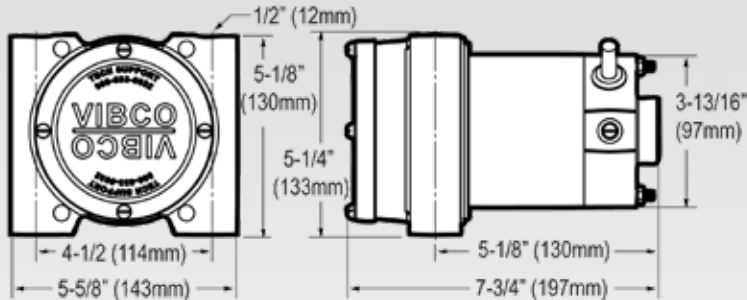

Weight	14.5lbs	6.6kg
Force	700 lbs	3115 Newtons
Amperage	25	13
Volts	12DC	24DC
Max Speed	5000	
dB	75	

Single Phase
Intermittent Operation

DESCRIPTION

- Cast Iron Housing, Corrosion Resistant.
- Also available as DC-700CD for Continuous Duty
- Silent Long Lasting Electric Unit
- Totally enclosed and can be used inside or outside, in dust, dirt, rain or snow.
- They solve a wide variety of problems - speeding the flow of bulk materials through any size bin, hopper or chute, packing material in drums and bags,
- Whatever your challenge, VIBCO has an electric vibrator solution.



HLF-700

NOT AFFECTED BY DIRT, NOR WET & MUDDY LOCATIONS

DESCRIPTION

- Durable Cast Iron Housing.
- VIBCO's Hydraulic Model HLF-700 is the smaller version of VIBCO's Big Buster HF
- These models are ideal for field or mobile applications and for smaller hoppers.
- These units are equipped with an internal coupling to minimize the wear of the hydraulic motor.
- The small and powerful high speed 9000 RPM vibrators offer an inexpensive solution to many material handling problems while operate on just 2.5 gallons per minute.

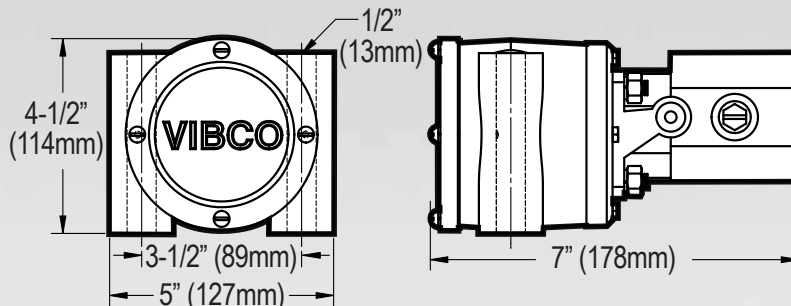

Weight	14.5lbs	6.6kg
Force	700 lbs	3115 Newtons
Amperage	25	13
Volts	12DC	24DC
Max Speed	5000	
dB	75	

*Single Phase
Intermittent Operation*

With it's unique design, premature failure of the drive unit is eliminated. This will drastically add to the unit life and eliminate costly shutdowns and maintenance expenditures. The unit can now be used continuously and also economically which is a big advantage over units made by others.

VIBCO offers a complete line of hydraulic vibrators to suit your needs. Our hydraulic vibrators operate in any position and are not affected by dirty, muddy or wet locations. Weighing just 14 pounds, the HLF-700 produces 700 lbs of centrifugal force.



HLF-700

HLF1300

SMALL BUT POWERFUL HIGH SPEED 9000 RPM VIBRATOR

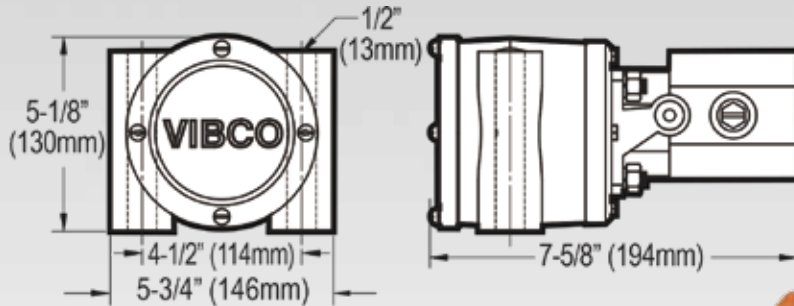

Weight	20lbs	9kg
Force	1300 lbs	5784 Newtons
Average PSI	1000	
Speed, VPM	9000	
Max GPM	2.8	
dB	72	

DESCRIPTION

- Durable Cast Iron Housing.
- VIBCO Hydraulic Vibrators can operate on pressures up to 3,000 PSI making them ideal for use with farm and construction equipment.
- The HLF-1300 at just 20 pounds operates up to 9000 vibrations per minute.

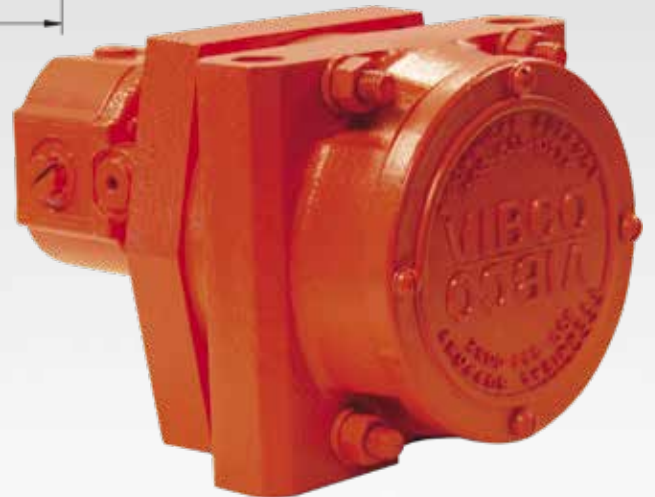

The HLF-1300 is ideal for large hoppers (and structures). These units are equipped with an internal coupling to minimize the wear of the hydraulic motor. The small and powerful high speed 9000 RPM vibrators offer an inexpensive solution to many material handling problems while operating with just 2.5 gallons per minute.

With its unique design, premature failure of the drive unit is eliminated. This will drastically add to the unit life and eliminate costly shutdowns and excessive maintenance expenditures. The unit can now be used continuously and also economically which is a big advantage over units made by others.

HLF-1300

TRAILA 150 STIK-IT MOUNT

PORTABLE DESIGN MAKES UNLOADING TRUCK AND TENDER HOPPERS QUICK & EFFICIENT

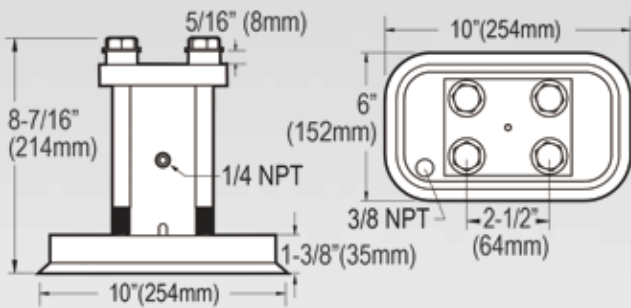

50 FOOT OF HOSE

VIBCO Traila™150
packs 40-100 lbs. of force



IN LINE LUBRICATOR

SAFETY CABLE



Weight	14.9 lbs	6.7kg
60psi (4Bar)	9 CFM	2,400 VPM
80psi (5.5Bar)	11 CFM	3,200 VPM
Weight of Material in Bin	400 to 1,000 lbs	180 to 455 kg

CFM = Cubic Feet per minute
 VPM = Vibration per minute

- VIBCO Traila™150 vibration system provides high impact and efficient energy transfer to ensure a smooth flow of material through fertilizer tenders, bins, chutes and other bulk material applications.
- Traila™150 is perfect for moving 1,000 pounds of material (or less) in the bin slope area. (For material in the bin slope area weighting over 1,000 lbs (455kg), consider using the Traila™ 200.)
- Both the 150 and 200 Traila Stik-it™ models move easily from hopper to hopper, requiring only one person to operate and move with no welding or mechanical attachment.
- Lightweight power – With a weight of under 14.9 lbs, the Traila™ 150 unit is a breeze to carry and activate where it is needed to maximize material flow.

Consider the maximum weight of material in the bin slope area and if it is between 400 and 1,000 pounds (180kg to 455 kg) then Traila™ 150 will deliver the right force and frequency to clear your toughest loads.

Attaches easily to your truck – VIBCO’s specialized air fitting simply attaches to your truck’s compression system. You can quickly swap between bins using nothing more than an air hose. A straightforward switch starts the suction and another starts the vibration. Redesigned for reduced weight and versatility, the Traila™ has the right force and frequency to clear your toughest loads.



TRAILA 200 STIK-IT MOUNT

SAVES WEIGHT AND MAKES UNLOADING TRUCK & TENDER HOPPERS EFFICIENT

VIBCO's Stik-It™ mount was designed just for the harsh dusty agricultural, industrial and construction environments. Our vacuum producer will pass large dust particles that will kill other units! Trucks, trailers, tenders, rail cars, any temporary material flow problem spots, hopper clean outs... all are perfect places to Stik-It™!

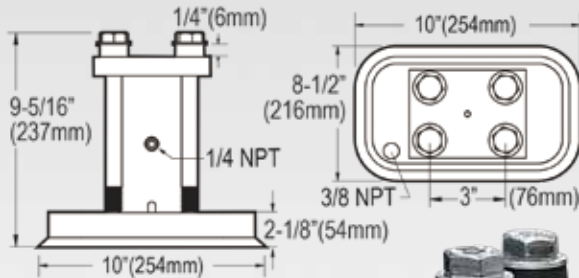

VIBCO Traila™200
packs 100-400 lbs. of force

Weight	21.4 lbs	9.6kg
60psi (4Bar)	12 CFM	2,400 VPM
80psi (5.5Bar)	15 CFM	3,000 VPM
Weight of Material in Bin	1,000 to 4,000 lbs	455 to 1,815 kg

CFM = Cubic Feet per minute
 VPM = Vibration per minute

**NO BOLTS,
 NO WELDING,
 NO HASSLE!
 Portable!**

- Runs on 15 CFM
- No more hammer damage
- Vacuum suction instantly holds using your truck's air supply

**50 FOOT
 OF HOSE**

**TRAILA
 STIK-IT™**

**SAFETY
 CABLE**

**IN LINE
 LUBRICATOR**

High temperature units available
 While our standard units cover a good temperature range from 32°F to 125°F (0°C to 51°C) our extreme range units take you to a higher and lower temperature zone, from -40°F to 450°F (-40°C to -232°C).

Traila 200™ can be quickly moved from hopper to hopper as needed with its suction activated base. There are no bolts, no welding, and no hassle involved! The suction is so effective, it even works on plastic tote bins, fiber drums bins and any other non-porous surface and securely attaches to hoppers on grain trailers and more.

55-2AB

PNEUMATIC UNIT FEATURES HIGH IMPACT LINEAR FORCE & EFFICIENT ENERGY TRANSFER

**Electrical
or Manual
SD-9057
Plumbing Kit
Available**

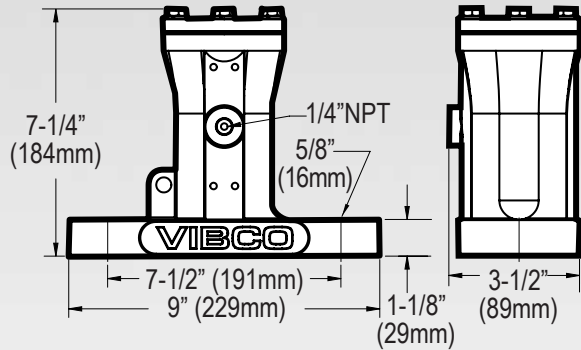

55-2AB HIGH IMPACT PISTON VIBRATOR

Adjustable Speed - Continuous Duty - Quiet

- Low Cost — fewer parts mean lower cost and less maintenance
- Reliability — built to last with simple design and heavy-duty construction
- Selection — a wide range of models to choose from so you get what you need
- Powerful — high impact, linear force and efficient energy transfer to ensure a smooth flow of material through fertilizer tender, bins, chutes and other bulk flow applications.

Weight	20lbs	9.1kg
40psi (2.8Bar)	7.5 CFM	3200 VPM
60psi (4Bar)	12 CFM	4000 VPM
80psi (5.5Bar)	15 CFM	5000 VPM
Weight of Material in Bin	4000 to 10,000 lbs	1814.4 to 4536 kg

*CFM = Cubic Feet per minute
VPM = Vibration per minute*



VIBCO VIBRATORS

PREFABRICATED MOUNTING HARDWARE BY VIBCO INSURES EFFICIENT ENERGY TRANSFER

USE VIBCO MOUNTING SYSTEMS FOR:

- Best transfer of vibration
- Protecting your equipment from damage due to wrongly mounted vibration solutions
- Systems are available for all vibrator styles
- Convenient and easy to mount.

This brochure shows just a small sampling of available vibration equipment to solve problems with material flow, and packaging.

Call for more information including 24/7 technical assistance, 800-633-0032, or check out our new General Catalog and more at www.vibcovibrators.com



#VIBCO SOLUTIONS

- ▶ ELECTRIC, PNEUMATIC & HYDRAULIC VIBRATORS
- ▶ AIR CANNONS
- ▶ RAIL ROAD CAR SHAKERS
- ▶ VIBRATING TABLES
- ▶ COMPACTORS & ROLLERS



RAILROAD CAR SHAKERS

- ▶ Largest Line, Light and Portable
- ▶ Electric, Pneumatic or Hydraulic
- ▶ Silent Models
- ▶ Catalog #9126

BIG BERTHA: Dump Body Vibrator

- ▶ Dump Body Vibrators
- ▶ How-to-Select Guide
- ▶ Drawing and Dimensions
- ▶ Catalog #BB08919

AIR CANNONS

- ▶ Patented Dual Piston Design
- ▶ Uses Normal Plant Air
- ▶ Install in any position
- ▶ Catalog #CAT-P-AC-09919

GENERAL CATALOG

- ▶ 84 Pages of Vibration Information
- ▶ Electric, Pneumatic & Hydraulic Models
- ▶ Application Photos
- ▶ Catalog #GC03124

GRAIN HANDLING EQUIPMENT

- ▶ For Feed Mills & Processing Facilities
- ▶ Trucks & Trailers
- ▶ Rail Car Shakers
- ▶ Air Cannons
- ▶ Catalog #AGF10024

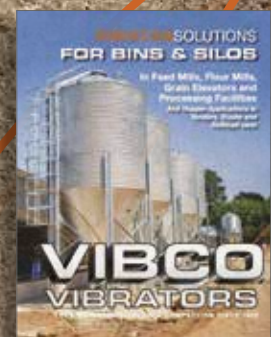
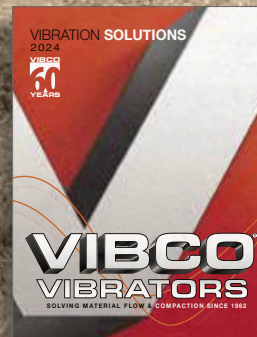
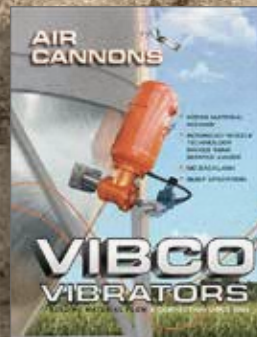
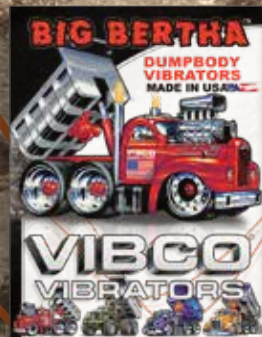
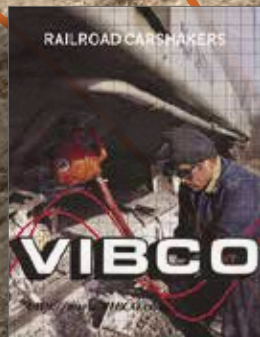

VIBCO® VIBRATORS

<http://www.VIBCO.com> • vibrators@vibco.com



#VIBCOsolutions

MADE IN USA

75 Stilson Road, Wyoming, RI 02898
Tel: 401.539.2392 • 800.633.0032

CANADA

2215 Dunwin Drive, Mississauga, Ont. L5L 1X1
Tel: 905.828.4191 • 800.465.9709